



Interlocking Block

An interlocking style block for both temporary and permanent structures



QUIKBLOC

Product Features

QuikBloc is an interlocking style block and is ideal for both temporary and permanent structures. The inter-locking blocks create a strong structure with no need for bonding or fixing. Installation is fast and simple as the blocks are manoeuvred using the lifting eye cast into the top of each block.

Product Dimensions

Product Type	Length (mm)	Width (mm)	Height (mm)	Weight (kg)
Full Block (Standard)	1400	700	700	1600
Half Block (Standard)	700	700	700	800
Full Block (Large)	1600	800	800	2350
Half Block (Large)	800	800	800	1175

The **interlocking principle** provides flexibility allowing structures to be modified or extended with ease. This also means that the blocks can be removed or relocated at any time.

Product Applications

QuikBloc has a variety of uses, including:

- Storage Bays
- Security Perimeters
- Scaffolding
- Earth Retention
- Partition Walls
- Material Segregation
- Coastal Defence

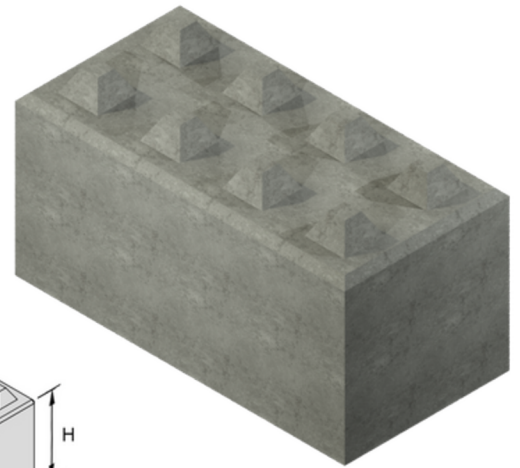
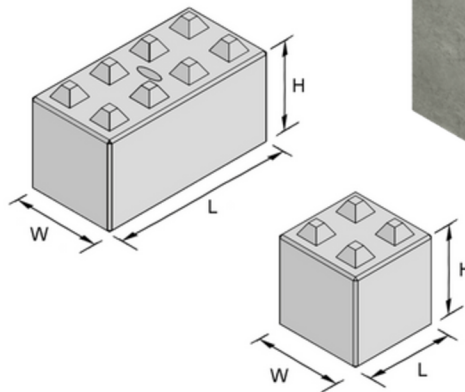

Suitable for the storage of bulk materials including:

- Aggregate
- Grain
- Road Salt/Grit
- Root Vegetables
- Recyclables/Waste
- Fertiliser
- Woodchip/Pellets
- Coal

Precast concrete interlocking blocks (QuikBloc) are manufactured to **EN 15258**. QuikBloc are designed by Chartered Structural Engineers in accordance with **EN1992:1-1** and BS EN 15258:2008.



Moore Concrete Products Ltd, Caherty House, 41 Woodside Road, Ballymena, County Antrim, Northern Ireland BT42 4QH

Tel: +44 (0) 28 2565 2566

Website: www.moore-concrete.com **Email:** sales@moore-concrete.com

INVESTORS IN PEOPLE®
We invest in people Gold

